



CORRUGATED PROCESS PRODUCT GUIDE



MAXCESS INTERNATIONAL COMPANIES



GUIDING · INSPECTION



TENSION CONTROL



SLITTING · WINDING

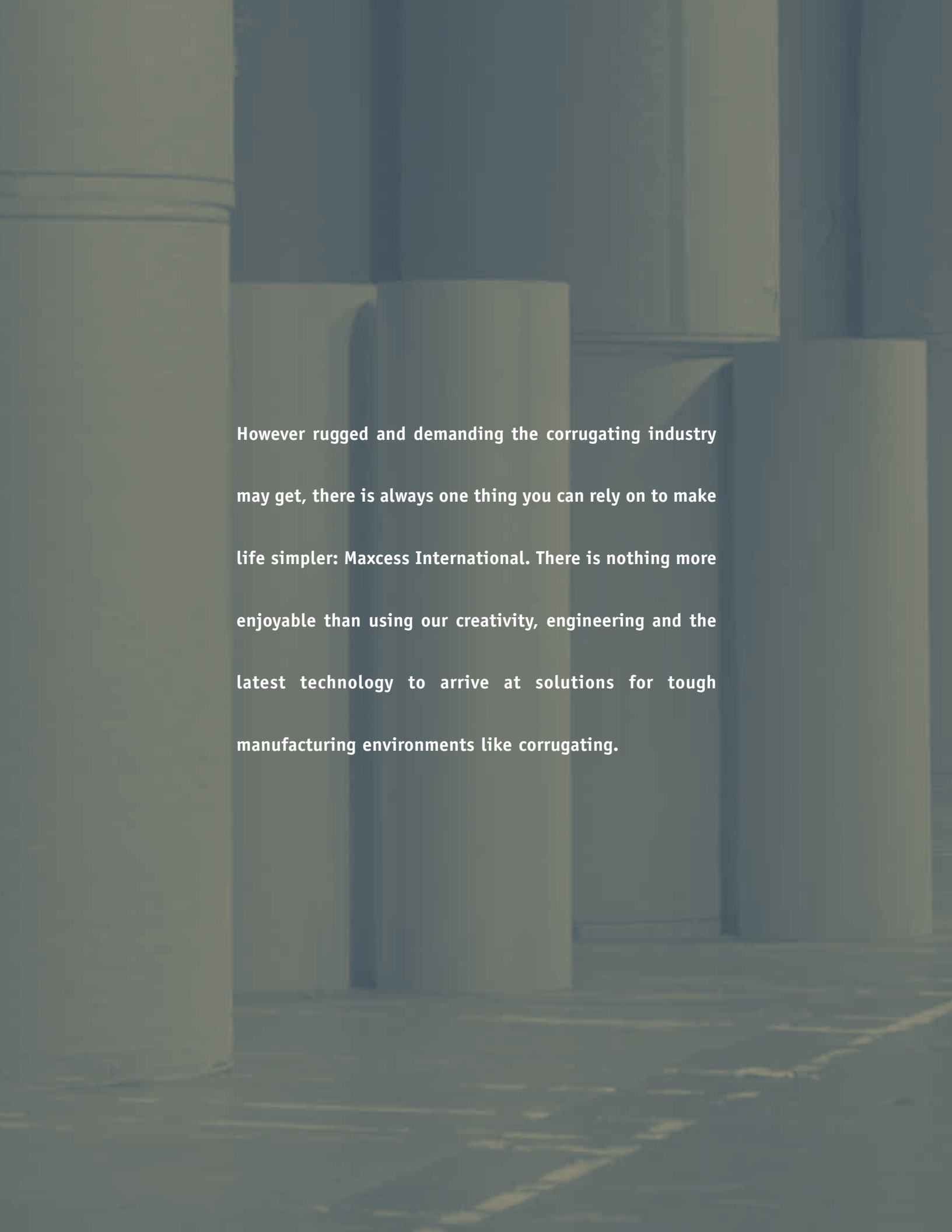

However rugged and demanding the corrugating industry may get, there is always one thing you can rely on to make life simpler: Maxcess International. There is nothing more enjoyable than using our creativity, engineering and the latest technology to arrive at solutions for tough manufacturing environments like corrugating.



Smart, dependable products specifically engineered for the corrugating industry.

T A B L E O F C O N T E N T S

Typical Corrugating Line	2-3
Bridge Guides by Fife	4-5
Slitter/Scorer Controls by Fife	6
Slitter/Scorer Shafts by Tidland	7
Shaftless Chucks by Tidland	8
Pneumatic Brakes by Tidland	9
Tension Control by MAGPOWR	10-11
Maxcess Product Lines	12
About Maxcess	13

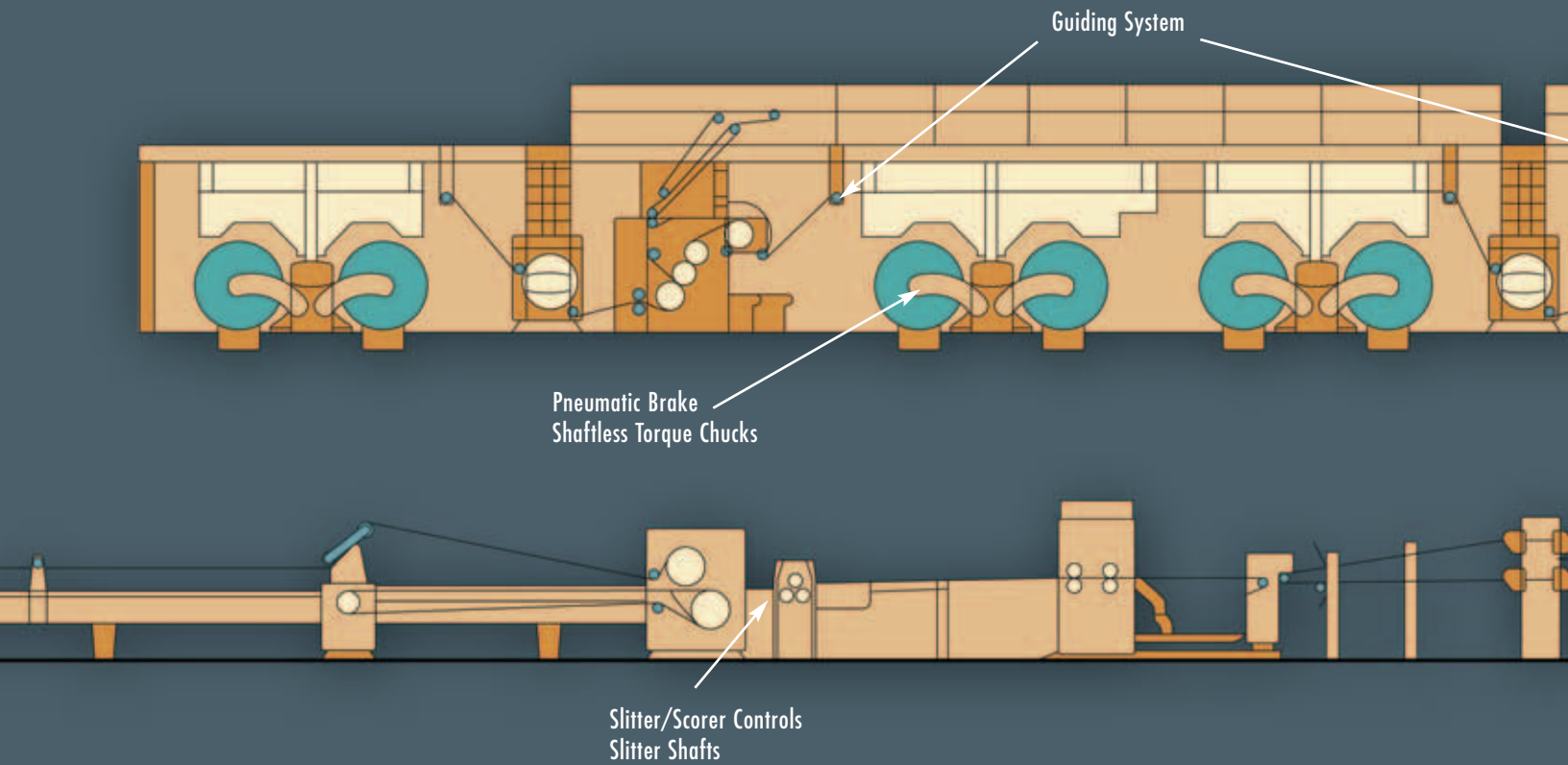

TYPICAL CORRUGATING LINE

Improving quality and reducing scrap

Maxcess International through its operating companies Fife, MAGPOWR and Tidland continuously strive to make products that enable you to get the most out of your operations. For those in the corrugating industry, that means focusing our efforts in several key areas:

- **PRODUCT DEPENDABILITY** - Our products are built to withstand the rugged and demanding environments found in the corrugating industry
- **SIMPLE INSTALLATION** - Improve the performance of your existing line with products that are easy to install and operate
- **LOW MAINTENANCE** - Advanced product designs ensure that routine maintenance is minimal and easy to perform
- **AFFORDABILITY** - Our products are competitively priced, and the return on investment is rapid due to reduced scrap and improved output

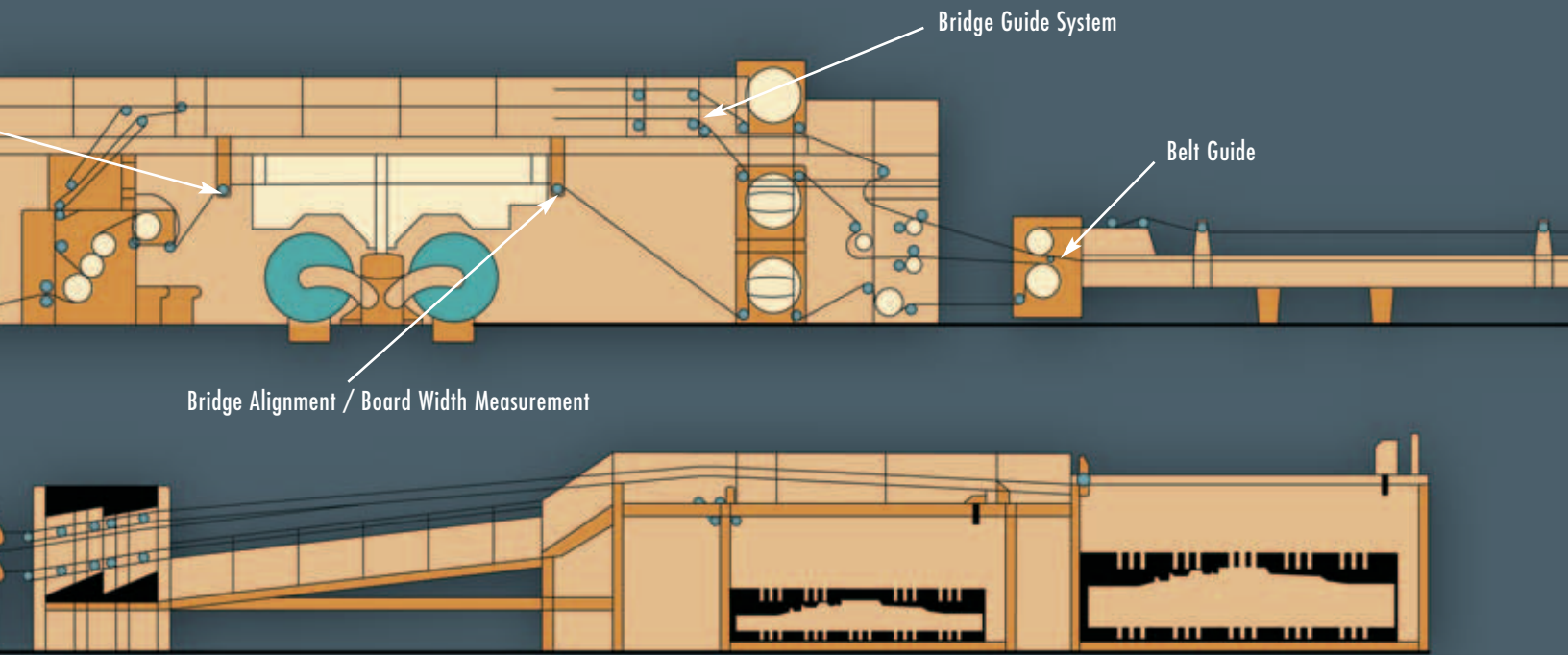

TYPICAL CORRUGATING LINE

Typical Process Lines

Whether you're investing in a new line or looking for retrofits, Fife Guiding, MAGPOWR Tension Control & Tidland Slitting and Winding products will help you reduce operating cost throughout your process line.

- On the Unwind - Shaftless Torque Chucks, Pneumatic Brakes, and Load Cells provide consistent, reliable tension
- On the Bridge - Bridge Guide Systems incorporate Guiding Systems, Load Cells, and Pneumatic Brakes to provide precise alignment of fluted medium to linerboards
- On the Tear Tape Dispenser - Guiding Systems maintain accurate placement of tear tape
- On the Slitter/Scorer - Guiding Systems accurately guide the linerboard by either edge, center guide or pre-printed line to the slitter/scorer to reduce waste. Slitter Shafts provide faster job changeovers when used to replace existing knife shafts on triplex style slitter/scorers

Control at any speed

Nearly 70 years of expertise is packed into each product we build. Whether you need a complete guiding system, or just a single component, you'll get optimal control no matter the application.

Bridge Guide

Designed specifically for corrugating applications, the bridge guide is typically installed prior to the double-backer. The bridge guide consists of Lazer*Wide SE-34 or Diode Array Camera (DAC) Sensors, steering guides and tension control.

This dedicated bridge guide system can accommodate either edge or center guiding applications for single, double, or triple-faced board, and board width monitoring with analog or digital output.

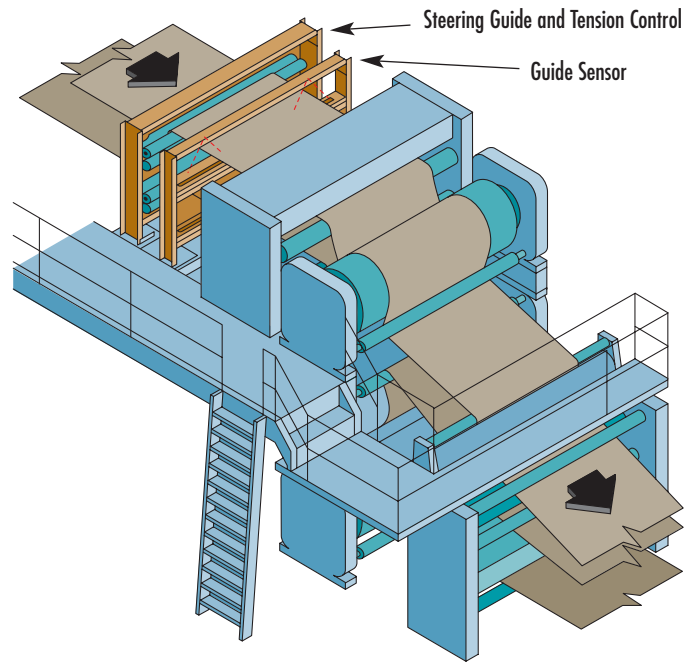

The Lazer*Wide or DAC sensors used on these bridge guides are immune to plane change and allow for board width variation and guide point shift without repositioning the sensors. This makes using the bridge guide easy. Operators need only pull the board through a starting point and begin guiding - no adjustments or changes necessary.



- Accurate board width monitoring
- No operator intervention required for width changes
- System components are built tough for demanding environments
- Eliminates the need for mechanical side guides, which may harm material
- Virtually maintenance-free, protected against dust, condensation and contaminants
- Optional Diode Array Camera (DAC) Sensors can be mounted away from the board to provide accurate guiding or board width monitoring with no operator adjustments or maintenance required

Sensors

LAZER*WIDE SE-34 SENSOR

The Lazer*Wide sensor is specifically designed for applications where varying board widths and multiple job changes are common. This unique sensor can have a control range of 2.44" to 200" (62 mm to 5080 mm) providing a wide sensor field of view without any moving parts for repositioning.

- Reliable, repeatable control
- Wide control range for either edge or center guiding
- Laser-based technology provides flexibility for board width measurement
- Configurable to any board width up to 200" (5080 mm)
- Unaffected by ambient light, including sunlight
- Flexible mounting and positioning assemblies ensure quick and easy installation



DAC-004 DIODE ARRAY CAMERA SENSOR

This digital sensor is unaffected by most in-plant contaminants. Its high-resolution diode array camera uses 7,450 pixels to detect contrast changes in its field of view.

- Suitable for all corrugated guiding applications
- Protected to IP 67 (DIN 40050) and operates in ambient conditions up to 50° C/125° F
- Durable aluminum housing with lens system protected by a glass filter

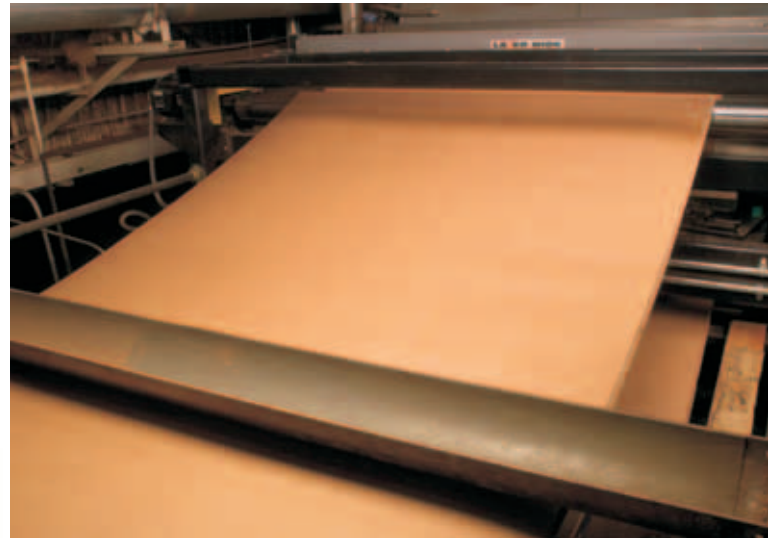

Controllers

D-MAX SERIES WEB GUIDE CONTROLLER

Advanced D-MAX Series Web Guiding systems deliver the highest level of guiding accuracy in the industry with an operator interface that is



easy to setup and operate. Ethernet connectivity makes D-MAX easy to network, while advanced features on the operator interface ensure consistency and reduce scrap.

- Intuitive setup and user-friendly operation reduces downtime between runs
- Operator Interface displays text or graphics to simplify setup and operation
 - IP 54 protection from harsh environments
 - Accessible from any PLC that communicates over ControlNet, DeviceNet, Ethernet Modbus TCP/IP, EtherNet/IP, Profibus, Profinet, CC Link, and CANopen

Corrugating Slitter/Scorer Controls

Slitter/scorer control systems provide accurate chasing of the slitter/scorer or triplexer section knives to the board at line speeds up to 1,000 fpm or more to reduce waste from side trim and order changes. These reliable systems utilize proven components that are easy to install on existing corrugating lines.

Fife slitter/scorer control systems use Diode Array Camera (DAC) or Lazer*wide sensors to view board edges or a pre-printed line. Digital output signals are amplified to control the power unit, which positions the slitter/scorer precisely, relative to the line, edge, or board center line.

In addition to Fife Slitter/Scorer controls, Fife belt guiding systems provide exact alignment of the belt through a closed-loop, fully proportional system. A self-contained electromechanical power unit, sensors and Kamberoller steering guides are typically used to position the belt and prevent off-tracking.

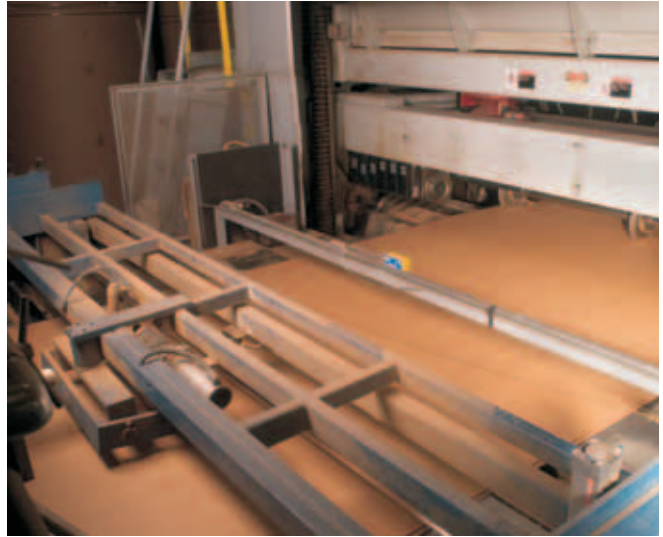

- Highly accurate, closed-loop, proportional controls eliminate the need for “on-off” systems or mechanical side guides, which can harm the belt or board edge
- Virtually maintenance-free, protected against dust, condensation and other contaminants
- Capable of centerline, either-edge and line guiding configurations
- When running pre-printed liner, camera sensors can be positioned to guide via download from an automatic order-change system
- Control systems are unaffected by width variations. Wide angle lenses cover minimum and maximum production widths, no operator intervention required
- Optional tear-tape dispenser control system accurately chases the tear-tape dispenser to the board to ensure consistent placement and reduce waste
- Fife belt guides improve placement of the board prior to the slitter/scorer and result in longer belt life

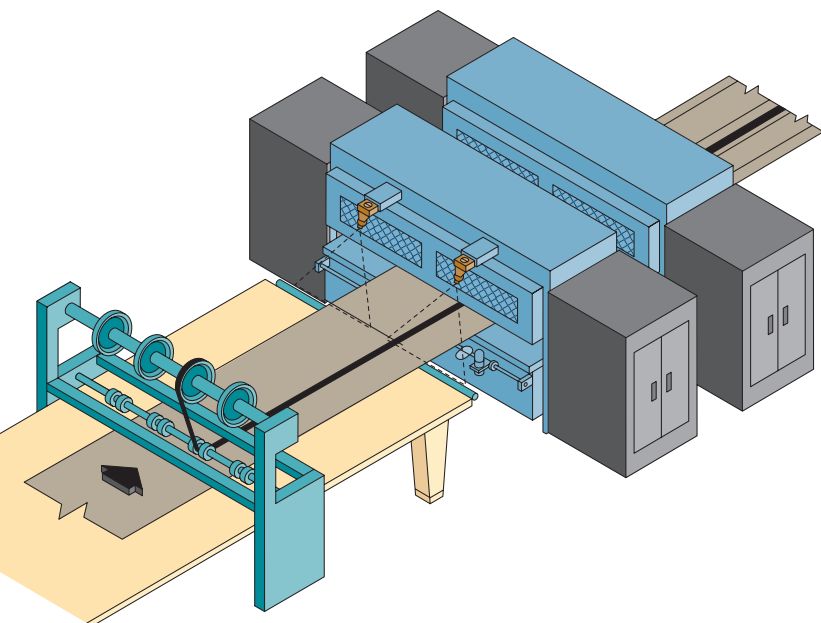

SLITTER / SCORER SHAFTS

BY TIDLAND

Sturdy and precise

Tidland slitter shafts keep you ahead of the game by delivering faster setup times.

Corrugating Slitter/Scorer Shafts

Tidland Slitter Shafts deliver significantly improved changeover time for triplexer style slitter/scorers. Each shaft is manufactured to your specific sizing and machine speed requirements and can be retrofitted to most triplexers, no matter the make of the machine. The shaft's expanding elements are specifically designed to securely lock slitter/scorer heads in position, while allowing easy and precise repositioning when needed. Operators no longer need any tools to reposition scorer and slitter blades.

Slitter shafts are available in the typical sizes of 6" and 8" for the corrugating industry, and can be manufactured for slitter head ID sizes up to 24" (610 mm). Slitter/scorer shafts are chrome plated with a Total Indicated Runout (TIR) of .002" (.051 mm) to minimize slitter head wobble.

Options for slitter shafts include:

- rotary union air system
- remote air valve
- key way with calibrated tape
- a variety of slitter scorer heads are available to suit your particular application, including split heads for easy removal from the slitter shaft



SERIES 950 GK SLITTER SHAFT

The Series 950 GK Slitter Shaft is designed for medium-duty applications. Durable construction, reliable grip, and fast, accurate positioning make this shaft ideal for rugged corrugating line applications. Expanding elements can be changed easily.

SERIES 900 KA SLITTER SHAFT

The Series 900 KA shaft has polyurethane-bonded metal leaves expanded by an internal rubber tube for positive grip of the slitter/scorer heads. This professional slitter shaft delivers superior balance and speed while greatly reducing downtime requirements for set up and maintenance.

- Designed to withstand mill and corrugating plant environments
- Fast and accurate repositioning of slitter/scorer heads
- Advanced strip design holds slitter/scorer heads firmly in place

SHAFTLESS CHUCKS

BY TIDLAND

Rugged and Dependable

Tidland core chucks and brakes take advantage of the latest technologies to keep your operations running smoothly and efficiently.

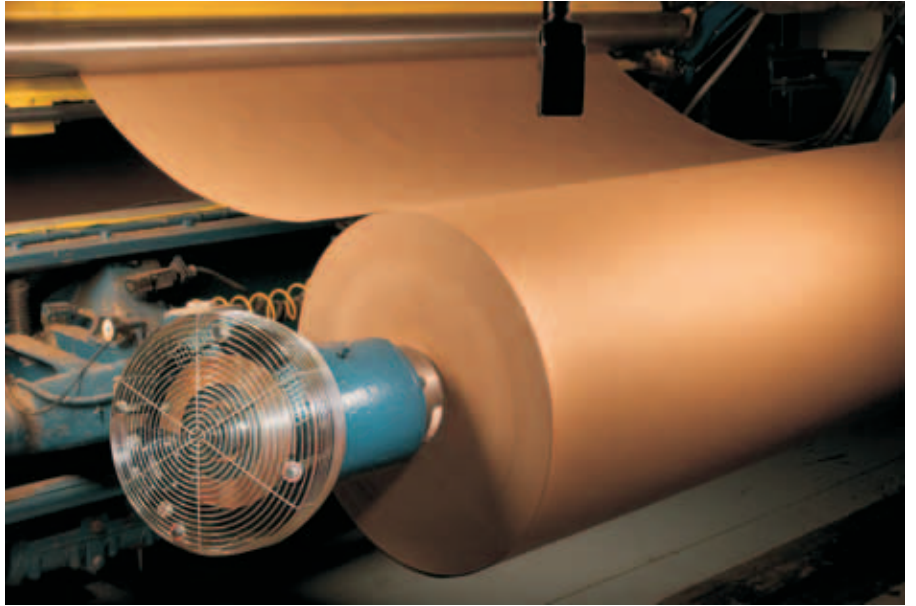

Corrugating Torque Chucks

Innovative and designed to meet the needs of the corrugating industry, the Raptor Series Torque Chucks are ideal in continuous-duty shaftless applications. Their unique design allows for maintenance and core size changes to be made without removing the entire chuck from the machine, reducing downtime as well as risk of injury to the operator.

These new chucks are a completely torque activated, bi-directional shaftless winding solution. They are extremely robust, easy to maintain, and deliver substantial torque output, with over 500 lb ft per chuck.

- Torque activated expansion provides maximum grip at all speeds
- No air supply is needed for expansion or retraction
- Disengagement requires no operator intervention or tools
- Available to suit a wide range of core sizes
- Durable construction for long life, low maintenance
- Absolute core centering minimizes roll vibration



Corrugating Pneumatic Brakes

The Tidland Pneumatic Brake provides the design specifications and operating sensitivity required to fully integrate tension control components. These durable brakes feature a heat dissipating design for maximum reliability, with models capable of handling a torque range of 1,430 inch-pounds to 23,700 inch-pounds.

Sturdy and simple, each brake can be built to meet your specific requirements. Disc diameter, caliper size, number of calipers and pad coefficients can all be adjusted to provide the ideal brake for your operation. Retrofit packages are available for common corrugator unwinds, they include:

- Standard brake package for Langston Unwinds
- Standard brake package for Martin Unwinds
- Custom retrofit packages are available



- When paired with MAGPOWR Tension Control Systems, Tidland pneumatic brakes provide automatic control and superior tension regulation for higher speed and greater accuracy
- Modular brake design with minimal moving parts offers application flexibility and ease of maintenance
- Easy retrofit and installation, designed for off-the-shelf configuration
- Opposing calipers are self-adjusting and require no special tools for servicing



TENSION CONTROL

BY MAGPOWER

Maximum output, minimum waste.

These advanced tension and torque control systems deliver accurate, reliable performance in any application.

CYGNUS® Tension Control

Compact and powerful, CYGNUS is a dramatically different tension control. With advanced yet easy to use features, tension is maintained or adjusted using multifunction “smart keys,” which are backlit for easy viewing. Operators can easily navigate through advanced tension control functions and codes, reducing setup times and improving productivity.

Operators are quickly guided through the setup process and fine-tune adjustments, without extensive training or the need of constantly referencing a separate manual. Corrugators can dramatically improve consistency with powerful features like automatic tuning, out of round roll compensation, web break detection, weightless load cell calibration, and gain scheduling.



- Multifunction “smart keys” for quick, easy setup
- Compact design - less than four inches in depth
- Features full-text prompts on backlit screen
- Provides web break detection and out of round roll compensation
- Bus communication capability using Ethernet, TCP/IP web server interface, or FTP client



Load Cells

MAGPOWR Load Cells are easy to install and ruggedly constructed, ideal for corrugated applications. These large, heavy-duty brakes provide ample torque for both tension and roll inertia requirements. Cast iron construction, high-heat dissipation and a wide operating range ensure reliable operation in the most demanding applications.

- Rugged construction to withstand mill environments
- Positive overload stops prevent damage
- Full wheat-stone bridge arrangement reduces the impact of drift through changes in temperature
- Simple to install



Pneumatic Brakes

In addition to Tidland, the MAGPOWR line provides you with a complete offering of pneumatic brakes. With ample torque for both tension and roll inertia requirements, these heavy-duty brakes are constructed entirely of cast iron to minimize the effects of thermal expansion. Available in 9", 13" or 17" (229 mm, 330 mm or 432 mm) diameters, these brakes are also vented to allow for greater heat dissipation.

- Disk assembly constructed of cast iron
- Vented for greater heat dissipation (23 hp)
- Quick disconnect fittings for quick, easy change of actuators and pads
- Machined guide posts for low pressure actuation
- Friction pads grooved for visual wear inspection, extra cooling and better control at high rpm's
- Modular construction - all parts are interchangeable
- Available in 9", 13" or 17" (229 mm, 330 mm or 432 mm) diameters
- Actuates with as little as 1/4 psi to accommodate a wide range of material
- Optional valve kits allow individual operation of friction pads for precise control over tension

Fife Guiding and Inspection

Controllers

Power Units

Sensors

Actuators

Positioners

Offset Pivot Guides

Steering Guides

Unwind/Rewind Guides

Visual & Video Web Inspection

Tidland Winding and Slitting

Ergonomic Shaft Solutions

Unwind, Rewind and Differential Core Shafts

Air Chucks

Brakes, Tension Control and Safety Chucks

Shaftless Chucks

Slitter Positioning Systems

Self-Contained Shear Slitting Systems

Mechanically Linked Slitting Systems

Performance Series Knifeholders

Blades

Slitter/Scorer Heads

Slitter/Scorer Knife Shafts

Digital Measurement Systems

MAGPOWR Torque and Tension Control

Load Cells

Tension Controls

Tension Readouts

Pneumatic Double Disk Brakes

Magnetic Particle Clutches and Brakes

Permanent Magnet Clutches and Brakes



Quality Products. One Company.

Maxcess International is the parent company of three proven industry leaders: FIFE, pioneers of web guiding; TIDLAND, inventors of the first air shaft; and MAGPOWR, providers of the largest installed base of tension control products in the industry.

Through these operating companies, Maxcess delivers over 130 combined years of experience, not to mention the most comprehensive line of web accessories available to make your operations run faster, straighter and more efficient.

Global Sales & Service

You can have local contact with Maxcess International no matter where you are in the world.

All of our sales teams are factory-trained on all product lines-slitting, winding, guiding, inspection & tension control-to help identify key areas where improvements can be made. So not only do you get the advanced products and systems you need, you get the localized sales and support you want.

Research & Development

For every web handling application, Maxcess is committed to developing innovative products and systems that are designed to improve overall efficiency and productivity of your operations. As a founding member of the Web Handling Research Center, we continue to improve our entire line of products, with an emphasis on advanced, software-driven products, as well as other emerging technologies.



MAXCESS INTERNATIONAL COMPANIES

WWW.MAXCESSINTL.COM



GUIDING · INSPECTION

1.405.755.1600



TENSION CONTROL

1.405.755.1600



SLITTING · WINDING

1.360.834.2345