



A Maxcess
International
Company

AG-9 Electromechanical Actuator



The AG-9 combines high thrust and variable gear ratios to deliver the flexibility you require. Capable of handling the most demanding applications, the AG-9 provides shiftable loads from 2,920 to 3,910 lbs (1,324 to 1,774 Kg), and incredibly fast shifting speeds of 0.66 to 0.50 in/sec (17 to 13 mm/sec). Standard actuator strokes range from 1" up to 10" inches (25.4 mm to 254 mm) in 1" (25.4 mm) increments, and 12" up to 18" (304.8 mm to 457 mm) in 2" (50.8 mm) increments.

Ball screw and nut design provides low-friction, efficient operation, and eliminates the typical end of stroke sticking and/or the need for actuator limit switches. This rugged actuator is widely used for steering guides, displacement guides, and unwind/rewind applications.

SPECS

General Specifications

Product Name:

AG-9 Electromechanical Actuator

Gearing Ratio:

9.8:1 up to 13.13:1

Motor Amps: 2.0**Maximum Motor RPM:** 1,560**Maximum Shiftable Load:**

2,920 lbs to 3,910
(1,324 to 1,774 Kg)
(using anti-friction bearings)

Maximum Design Thrust:

292 to 391 lbf
(1,299 to 1,739 N)

Maximum Shifting Speed:

0.66 to 0.50 in/sec
(17 to 13 mm/sec)

Key Features:

- Fast, accurate operation—shifting speeds of 0.66 up to 0.50 in/sec (17 to 13 mm/sec).
- Gear-driven actuator with shiftable loads up to 3,910 lbs (1,774 Kg).
- Clean, electronic operation.
- Durable construction for continuous-duty reliability.
- Nonsticking end of stroke design.
- No limit switches required.
- Compatible with all Fife automated guiding and positioning equipment.
- Sized and configured to your requirements.

KEY
FEATURES

AG-9 WITH FLANGE

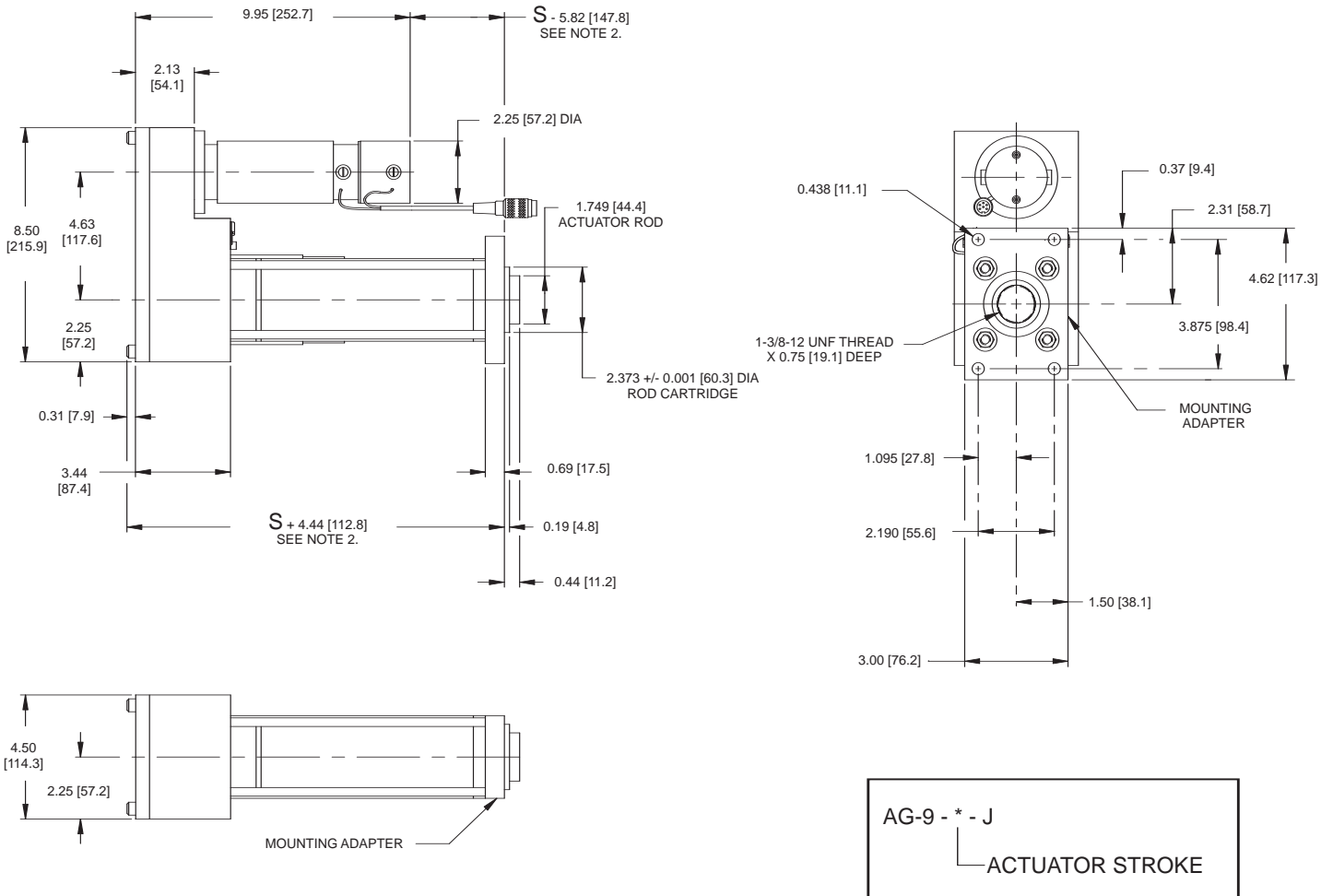

AG-9 - * - J

└── ACTUATOR STROKE

NOTES:

1. This drawing shows an actuator with a rectangular flange mounting adapter.
2. Actuators with strokes $\leq 4''$ (102) $S = 8.25$ (210)
 Actuators with strokes $> 4''$ (102) $S = \text{stroke} + 4.25$ (108)
3. Rotary motion of the actuator rod will produce linear movement of the actuator.
 The connection to the rod must be rigid, and not free to turn.
4. All dimensions in parenthesis are in millimeters.

AG-9 WITH CLEVIS MOUNT

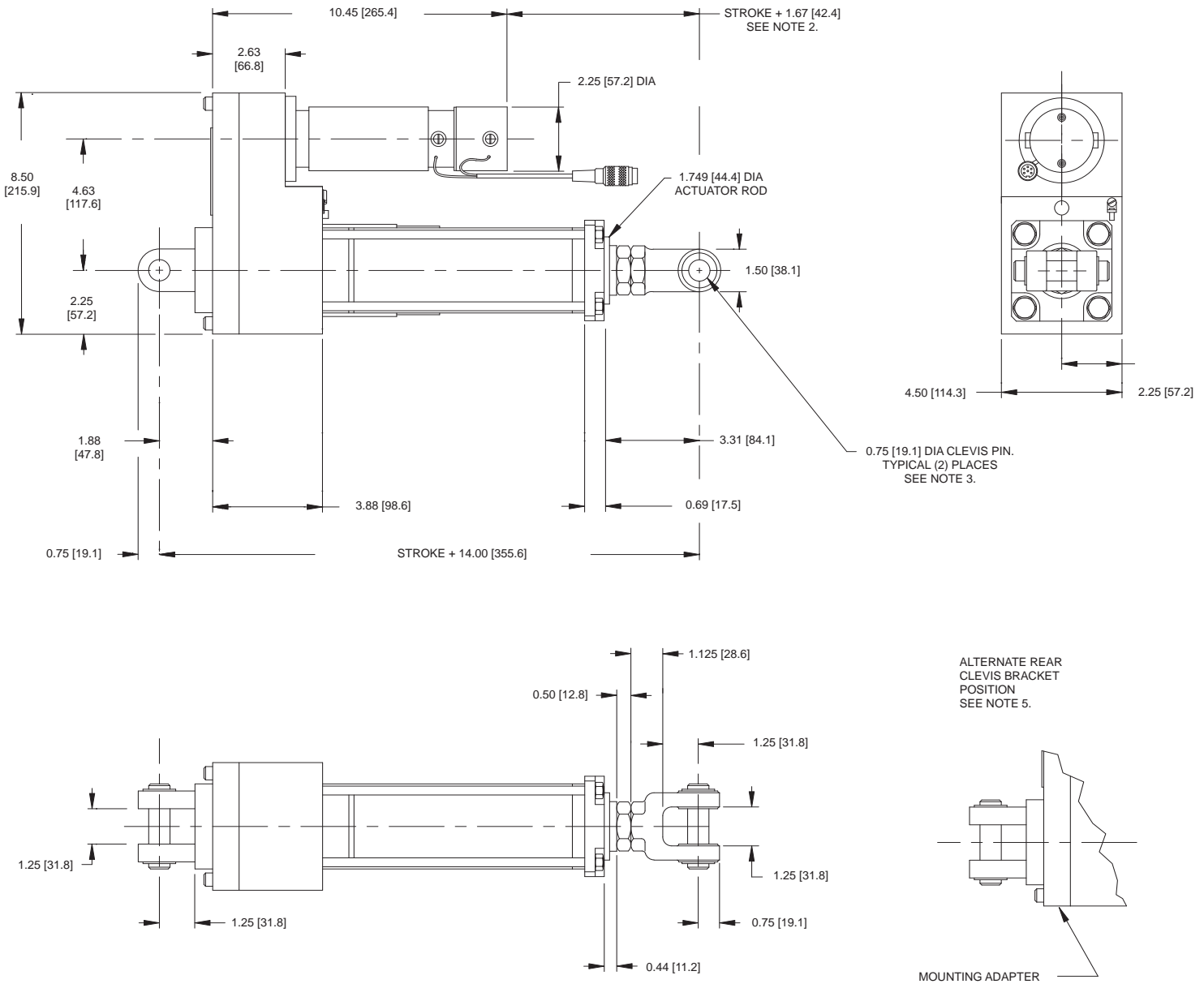

NOTES:

1. This drawing shows an actuator with a clevis adapter.
2. The noted gap between the rear of the motor and the pivot point becomes small on short stroke actuators. Check the installation to ensure there will not be any interference.
3. Each actuator is supplied with two clevis pins and four cotter pins or snap rings.
4. Rotary motion of the actuator rod will produce linear movement of the actuator. The connection to the rod must be rigid, and not free to turn.
5. To change the orientation of the rear clevis bracket, it is necessary to remove the rear cover plate.
6. All dimensions in parenthesis are in millimeters.

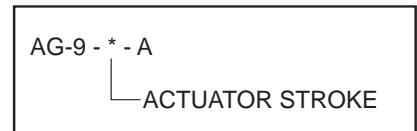

AG-9 Model Specifications

Model Number	Gear Ratio	Motor Amps	Max. Motor rpm	*Max. Shiftable Load lbs (Kg)	Max. Design Thrust lbf (N)	Max. Shifting Speed In/Sec (mm/Sec)
AG-9-10	9.8:1	2.0	1,560	*2,920 (1,324)	292 (1,299)	0.66 (17)
AG-9-13	13.125:1	2.0	1,560	*3,910 (1,773)	391 (1,739)	0.50 (13)

*Based on using anti-friction bearings

Complementary Products:

FIFE

Guiding Products & Systems

- CDP-01 Web Guide Controller
- Offset Pivot Guides
- KAMBEROLLER® Guides

Inspection Products & Systems

TIDLAND

Slitting Products & Systems

Winding Products

MAGPOWR

Tension Control Products

Torque Control Products



A Maxcess International Company

Fife Corporation

222 West Memorial Road
Oklahoma City, OK 73114, USA
Phone: 405-755-1600
Fax: 405-755-8425
E-mail: fife@fife.com
Web: www.fife.com

Fife-Tidland GmbH

Fifestrasse 1, D-65779
Kelkheim/Ts., Germany
Phone: (49) 6195-7002-0
Fax: (49) 6195-7002-933
E-mail: info@maxcess.de

Maxcess Asia

300 Orchard Road, No. 15-05
Orchard Towers
Singapore 238875
Phone: (65) 6834-1998
Fax: (65) 6835-4818
E-mail: asia@maxcessintl.com



MAXCESS INTERNATIONAL COMPANIES



GUIDING · INSPECTION

1-800-639-3433
(405) 755-1600



TENSION CONTROL

1-800-MAGPOWR
(405) 755-1600



SLITTING · WINDING

1-800-426-1000
(360) 834-2345